



SK80-BFTLFT-AFF-WMT KNX-Sensor

Soil moisture and temperature & Humidity and air temperature

SK80-BFTLFT-AFF-WMT	Soil sensor
	
Soil moisture and temperature Humidity and air temperature	Soil moisture and temperature Watermark® replacement sensor

Item description	Article number	Description
SK80-BFTLFT-AFF-WMT	30805121	Measuring electronics with Watermark® Integrated air humidity and temperature sensor
SK80-BFTLFT-AFF	30805120	Measuring electronics without Watermark® Integrated air humidity and temperature sensor
Watermark® replacement sensor	91100000	Standard length 5m can be ordered individually up to 50 metres

Device description

The SK80-BFTLFT-AFF-WMT measuring system records soil moisture, which is measured using the Watermark® sensor, as well as soil temperature. The measuring system also has sensors for air humidity and air temperature, so it can provide a more comprehensive picture of the current situation in the garden or greenhouse.

Table of contentsts

Content
Applications
Technical data
Installation instructions for the Watermark soil sensor
Irrigation
Commissioning
ETS setting
General settings
Measured value soil moisture
Controller soil moisture / variants
Measured value soil temperature
Controller soil temperature / variants
Dewpoint temperature
Absolute humidity
Humidity
Controller humidity / variants
Air temperature
Controller air temperature / variants
Status objects
ETS Objects
Notes
Controller
Discharge Program and Reset Sensor
Imprint

Applications

Irrigation of outdoor vegetables, asparagus and soft fruit using a sprinkler machine, in viticulture, for tree fruit, hops, potatoes, sugar beet, arable farming and seed production, as well as applications in garden and lawn irrigation, golf course or sports field irrigation and in landscaping.

The sensor is not suitable for potted plants and similars.

Technical data

SK80-BFTLFT-AFF-WMT	
Supply voltage	KNX 21 .. 32V DC
KNX load	10mA
Operating/storage temperature bus coupler	-25 .. +60°C / -25 .. +80°C
Environmental humidity	0 .. 100% non-condensing
Dimensions	see drawing
ETS-application	Arc_S8.knxprod / S8-BFTLFT
Protection class bus coupler	IP54/65
Soil moisture Watermark®	
Measuring range	0 .. ~220000 Pa
Resolution	± 0,01 Pa
Soil temperature PT1000	
Measuring range	-25 .. +50°C
Resolution / accuracy	± 0,01°C / Klasse DIN B
Air humidity	
Measuring range	0 .. 100% r.H
Resolution / accuracy	0,02% / ±3% r.H (20..80%) at +20°C, else ±5%
Air temperature	
Measuring range	-25 .. +80°C
Resolution / accuracy	0,02°C / ±0,4°C (5..60°C), else ±0,8°C

Dimensions and connections

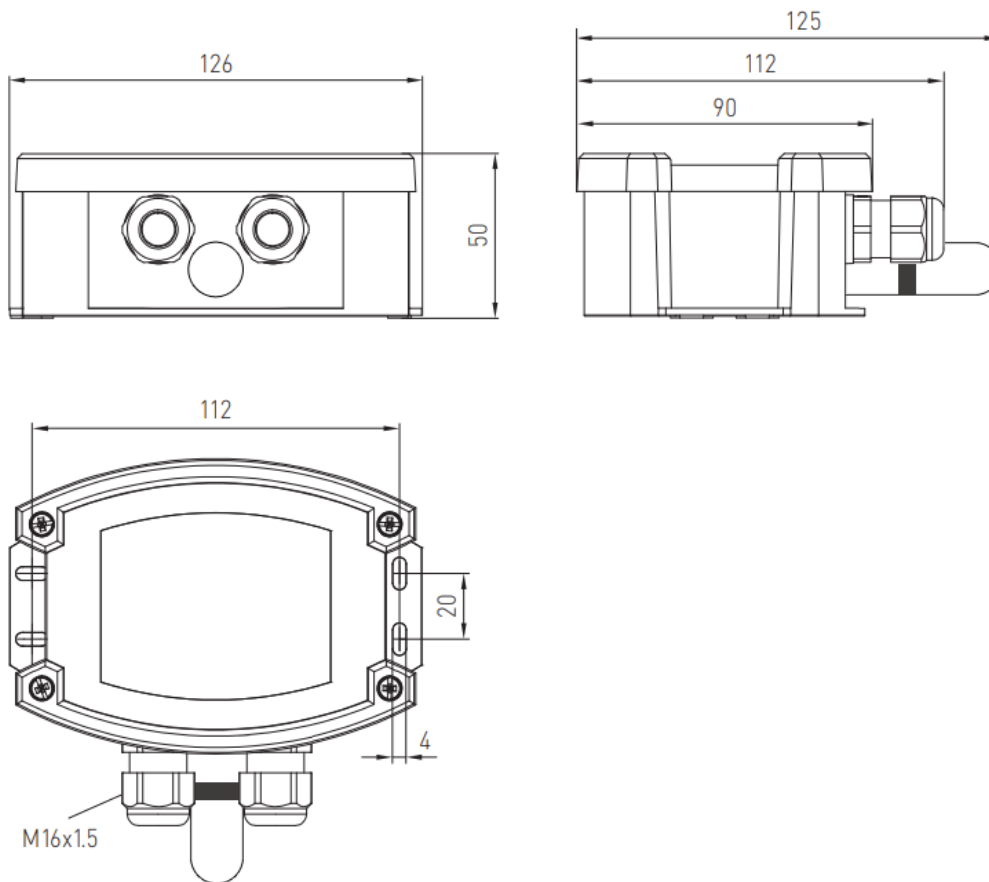

Inside view	Connections
	<p>BF: Soil moisture Wire 1 & 2 polarity-free</p> <p>TMP: Soil temperature Wire 3 & unlabelled polarity-free</p> <p>S1: Switch input S2: Switch input</p> <p>The switch inputs are potential-free.</p>

Installation instructions for the Watermark soil sensor

Description

The Watermark[®] sensor is a hassle-free, user-friendly sensor, as watermarks are maintenance-free and frost-proof, and buffered against fluctuating salt content in the soil solution. The sensors response sensitivity ranges from several hours to one day, depending on the soil type.

The sensor cable can be extended up to 50 metres.

Preparation

Watermark[®] soil moisture sensors should always be conditioned before use. To do this, the sensors are placed in water overnight and then dried completely. This process should be repeated twice. Before installation in the ground, the sensors must be completely moist, i.e. they must be watered again for several hours before installation.

Watermark[®] sensors that have been conditioned react quickly to changing moisture conditions in the soil right from the start. If the sensors could not be conditioned before installation but are saturated with water, it will take several days for them to respond quickly to changes in soil moisture. Once the sensors have been watered, they are ready for installation.

Installation

The correct installation depth for soil sensors depends on the plant species and its root depth in order to ensure optimal measurement for irrigation. For most ornamental plants or lawns, the depth is typically around 5–10 cm.

Root zone as a guideline:

Install the sensor at the depth where the plants absorb the most water.

Good ground contact:

Ensure that the sensor is completely surrounded by soil. Cover the watered sensor with a mixture of soil and water.

Irrigation

Basics

The amount of water required depends on:

- **Soil type** (sand, loam, clay, mixed soil)
- **Root depth** of the plants
- **Weather** (temperature, wind, solar radiation)
- **Plant species** (vegetables, lawn, fruit, trees and shrubs)

Target: Keep the soil **evenly moist**, but **avoid waterlogging**.

Time-controlled irrigation

The response sensitivity of the sensor ranges from several hours to one day, depending on the soil type. For this reason, controlled irrigation with regulators is not necessarily suitable. It is better to use time-controlled irrigation, which is started with the help of the limit value objects for soil moisture. Observe the planting and, if necessary, adjust the limits for an optimal result that can be achieved under the given conditions.

Guidelines for lawn watering quantities

Recommended activation points and watering rates for the main soil types to moisten the soil layer 0–30 cm

	Recommended range for 'rich green'	Water-saving range for 'conservation irrigation'
Switching point for irrigation soil type	10000 to 50000 Pa 10 to 50 centibar	50000 to 150000 Pa 50 to 150 centibar
sand	8 l/m ² per addition	4 l/m ² per addition
mixed soil	10 l/m ² per addition	5 l/m ² per addition
loam	15 l/m ² per addition	20 l/m ² per addition
sandy loam	15 l/m ² per addition	15 l/m ² per addition
silty loam	6 l/m ² per addition	20 l/m ² per addition
clay	6 l/m ² per addition	20 l/m ² per addition

Commissioning

Displays on the device

The current values are displayed on the device and output on the KNX bus.

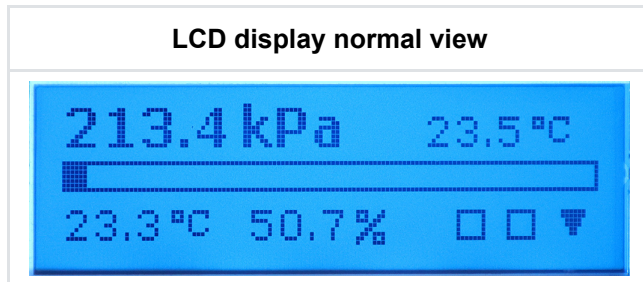

- actual soil moisture in kPa (Bar indicates soil moisture)
- actual soil temperature (top right)
- actual air temperature
- actual relative humidity
- Switching input S1 left inactive active
- Switching input S2 right inactive active
- Switching output S3 inactive active

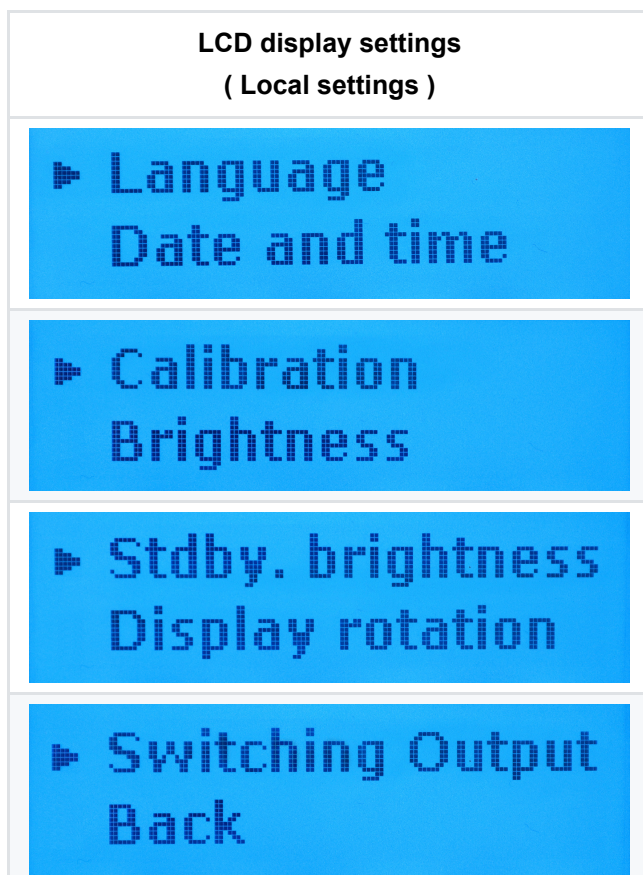

Operation via the buttons:

- Pressing the button (o) opens the settings.
- A short press of the button (o) enters the next menu item, jumps to the next digit or accepts the current value.
- Long press of the button (o) exits the current menu item without changing it or goes to the previous digit.
- The +/- buttons select the previous/next menu item or increment/decrement the current digit.

Changes to the parameters must be confirmed via a dialogue (Apply/Cancel).

The following settings can be made using the operating buttons:

- Language
 - German
 - English
 - Spanish

- Date/Time

The date and time are only used for the display and the timer function.

- Calibration

Calibration of the evaluation unit for connecting the Watermark[®] soil moisture sensor.
Already done at the factory.

- Brightness

- Brightness of the display during operation
0 - 5 - 10 - 20 - 40 - 70 - 100 %

- Standby brightness

- Brightness of the display in standby mode
0 - 5 - 10 - 20 - 40 - 70 - 100 %

- Rotate display

- Display is rotated by 180°

- Switching output S3

Not available as standard

- back

- Back to normal view

ETS setting

General settings

General settings	Measured value send cycle period	1 Min
Measured value soil moisture	Actuating value send cycle period (Seconds)	60
Controller soil moisture	Use clock timer	<input type="radio"/> No <input checked="" type="radio"/> Yes
Measured value soil temperature	Timer from	0
Controller soil temperature	Timer until	24

Parameter	Setting
Measured value send cycle period	1 .. 120 min
Actuating value send cycle period (Seconds)	10 .. 250
Use clock timer	no / yes
Timer until	0 .. 24 clock
Timer from	0 .. 24 clock

If the timer is used, the controllers are active in the periods between 'Timer from' to 'Timer until'. The prerequisite is that the 'Use timer' parameter in the 'Controller' parameter field is activated.

The device loses the date and time in the event of a power failure.

The date and time must be set again.

It therefore makes sense to connect objects **58:Time** and **59:Date** to a time server.

Measured value soil moisture

General settings	Measured value send cyclical	<input checked="" type="radio"/> No <input type="radio"/> Yes
Measured value soil moisture	Measured value send by change	<input checked="" type="radio"/> No <input type="radio"/> Yes
Controller soil moisture	Type datapoint	<input checked="" type="radio"/> 2byte float <input type="radio"/> 4byte float
Measured value soil temperature	Auxiliary object is	Setpoint
Controller soil temperature	Auxiliary value store by change	<input checked="" type="radio"/> No <input type="radio"/> Yes
Dewpoint temperature	Lower limit (hPa)	100
Absolute humidity	Upper limit (hPa)	600
Humidity	Differential gap send/limits x 0,01	50

Parameter Measured value soil moisture	Settings / Description
Measured value send cyclical	no / yes
Measured value send by change	no / yes
Type datapoint	KNX data type for measured value
Auxiliary object is	- Setpoint - Upper limit - Lower limit Parameter that can be changed via the auxiliary object.
Auxiliary value store by change	no / yes
Lower limit x hPa	0 .. 1400 If the measured value is below this limit, the object 'lower limit' is set. Note any changes due to auxiliary size.
Upper limit x hPa	0 .. 1400 If the measured value exceeds this limit, the object 'upper limit' is set. Note any changes due to auxiliary size.
Differential gaps send/limits x hPa	0 .. 1400 Is symmetrically above the limit values as hysteresis.

Controller soil moisture / variants

Soil moisture - Steady PI controller

General settings	Locking object	<input checked="" type="radio"/> locked if 1 <input type="radio"/> locked if 0
Measured value soil moisture	Actuating value by ascending actual value	<input type="radio"/> increasing <input checked="" type="radio"/> decreasing
Controller soil moisture	Controller	Steady PI controller
Measured value soil temperature	Setpoint (hPa)	300
Controller soil temperature	Proportional range (hPa)	100
Dewpoint temperature	Reset time (in minutes)	150
Absolute humidity	Actuating value send cyclical	<input checked="" type="radio"/> No <input type="radio"/> Yes
Humidity	Actuating value distance to limit in %	0
Controller humidity	Use clock timer	<input checked="" type="radio"/> No <input type="radio"/> Yes

Parameter Steady PI controller	Settings / Description
Locking object	1 / 0 lock the controller at "1" oder "0"
Actuating value by ascending actual value	increasing / decreasing control direction
Controller	Select controller type
Setpoint (in hPa)	0 .. 1400 Note any changes due to auxiliary variables.
Proportional range (in hPa)	0 .. 1400
Reset time (in Minuten)	0 .. 255
Actuating value send cyclical	No / Yes
Actuating value distance to limit in %	0 .. 50
Use clock timer	No / Yes The time is set in the 'General settings' parameter field.

Soil moisture - Switched PI controller (PWM)

General settings	Locking object	<input checked="" type="radio"/> locked if 1 <input type="radio"/> locked if 0
Measured value soil moisture	Actuating value by ascending actual value	<input type="radio"/> increasing <input checked="" type="radio"/> decreasing
Controller soil moisture	Controller	Switched PI controller (PWM)
Measured value soil temperature	Setpoint (hPa)	300
Controller soil temperature	Proportional range (hPa)	100
Dewpoint temperature	Reset time (in minutes)	150
Absolute humidity	Actuating value send cyclical	<input checked="" type="radio"/> No <input type="radio"/> Yes
Humidity	Actuating value distance to limit in %	0
Controller humidity	Cycle duration in seconds	60
Air temperature	Use clock timer	<input checked="" type="radio"/> No <input type="radio"/> Yes

Parameter Switched PI controller (PWM)	Settings / Description
Locking object	1 / 0 lock the controller at "1" oder "0"
Actuating value by ascending actual value	increasing / decreasing control direction
Controller	Select controller type
Setpoint (in hPa)	0 .. 1400 Note any changes due to auxiliary variables.
Proportional range (in hPa)	0 .. 1400
Reset time (in Minuten)	0 .. 255
Actuating value send cyclical	No / Yes
Actuating value distance to limit in %	0 .. 50
Cycle duration in seconds	0 .. 65535
Use clock timer	No / Yes The time is set in the 'General settings' parameter field.

Soil moisture - Two-Position Controller

General settings	Locking object	<input checked="" type="radio"/> locked if 1 <input type="radio"/> locked if 0
Measured value soil moisture	Actuating value by ascending actual value	<input type="radio"/> increasing <input checked="" type="radio"/> decreasing
Controller soil moisture	Controller	Two-Position Controller
Measured value soil temperature	Setpoint (hPa)	300
Controller soil temperature	Differential gap Controller (hPa)	100
Dewpoint temperature	Actuating value send cyclical	<input checked="" type="radio"/> No <input type="radio"/> Yes
Absolute humidity	Use clock timer	<input checked="" type="radio"/> No <input type="radio"/> Yes

Parameter Two-Position Controller	Settings / Description
Locking object	1 / 0 lock the controller at "1" oder "0"
Actuating value by ascending actual value	increasing / decreasing control direction
Controller	Select controller type
Setpoint (in hPa)	0 .. 1400 Note any changes due to auxiliary variables.
Differential gab Controller (in hPa)	0 .. 1400 The switching point hysteresis is symmetrical above the setpoint.
Actuating value send cyclical	No / Yes
Use clock timer	No / Yes The time is set in the 'General settings' parameter field.

Soil moisture - Two-Position Controller Pulsed

General settings	Locking object	<input checked="" type="radio"/> locked if 1 <input type="radio"/> locked if 0
Measured value soil moisture	Actuating value by ascending actual value	<input type="radio"/> increasing <input checked="" type="radio"/> decreasing
Controller soil moisture	Controller	Two-Position Controller Pulsed
Measured value soil temperature	Setpoint (hPa)	300
Controller soil temperature	Differential gap Controller (hPa)	100
Dewpoint temperature	Actuating value send cyclical	<input checked="" type="radio"/> No <input type="radio"/> Yes
Absolute humidity	Duty cycle in %	30
Humidity	Cycle duration in seconds	1800
	Use clock timer	<input checked="" type="radio"/> No <input type="radio"/> Yes

Parameter Two-Position Controller Pulsed	Settings / Description
Locking object	1 / 0 lock the controller at "1" oder "0"
Actuating value by ascending actual value	increasing / decreasing control direction
Controller	Select controller type
Setpoint (in hPa)	0 .. 1400 Note any changes due to auxiliary variables.
Differential gab Controller (in hPa)	0 .. 1400 The switching point hysteresis is symmetrical above the setpoint.
Actuating value send cyclical	No / Yes
Duty cycle in %	0 .. 50
Cycle duration in seconds	0 .. 65535
Use clock timer	No / Yes The time is set in the 'General settings' parameter field.

Measured value soil temperature

General settings	Measured value send cyclical	<input checked="" type="radio"/> No <input type="radio"/> Yes
Measured value soil moisture	Measured value send by change	<input checked="" type="radio"/> No <input type="radio"/> Yes
Controller soil moisture	Type datapoint	2byte float
Measured value soil tempera...	Auxiliary object is	Setpoint
Controller soil temperature	Auxiliary value store by change	<input checked="" type="radio"/> No <input type="radio"/> Yes
Dewpoint temperature	Lower limit (x 0,01 °C)	700
Absolute humidity	Upper limit (x 0,01 °C)	1700
Humidity	Measured value shift (x 0,01 °C)	0
Controller humidity	Differential gap send/limits (x 0,01 °C)	50

Parameter Measured value soil temperature	Settings / Description
Measured value send cyclical	no / yes
Measured value send by change	no / yes
Type datapoint	KNX data type for measured value
Auxiliary object is	- Setpoint - Upper limit - Lower limit Parameter that can be changed via the auxiliary object.
Auxiliary value store by change	no / yes
Lower limit (x 0,01°C)	-9999 .. 9999 If the measured value falls below this limit, the 'Lower Limit' object is set. Note any changes due to auxiliary variables.
Upper limit (x 0,01°C)	-9999 .. 9999 If the measured value exceeds this limit, the object 'upper limit' is set. Note any changes due to auxiliary variables.
Measured value shift (x 0,01°C)	-32768 .. 32767
Differential gap send/limits (x 0,01°C)	-9999 .. 9999 Is symmetrically above the limit values as hysteresis.

Controller soil temperature / variants

Soil temperature - Steady PI controller

General settings	Locking object	<input checked="" type="radio"/> locked if 1 <input type="radio"/> locked if 0
Measured value soil moisture	Actuating value by ascending actual value	<input type="radio"/> increasing <input checked="" type="radio"/> decreasing
Controller soil moisture	Controller	Steady PI controller
Measured value soil temperature	Setpoint (x 0,01 °C)	1800
Controller soil temperature	Proportional range (°C)	5
Dewpoint temperature	Reset time (in minutes)	150
Absolute humidity	Actuating value send cyclical	<input checked="" type="radio"/> No <input type="radio"/> Yes
Humidity	Actuating value distance to limit in %	0
Controller humidity	Use clock timer	<input checked="" type="radio"/> No <input type="radio"/> Yes

Parameter Steady PI controller	Settings / Description
Locking object	1 / 0 lock the controller at "1" oder "0"
Actuating value by ascending actual value	increasing / decreasing control direction
Controller	Select controller type
Setpoint (x 0,01°C)	-9999 .. 9999 Note any changes due to auxiliary variables.
Proportional range (x 0,01°C)	-9999 .. 9999
Reset time (in Minuten)	0 .. 255
Actuating value send cyclical	No / Yes
Actuating value distance to limit in %	0 .. 50
Use clock timer	No / Yes The time is set in the 'General settings' parameter field.

Soil temperature - Switched PI controller (PWM)

General settings	Locking object	<input checked="" type="radio"/> locked if 1 <input type="radio"/> locked if 0
Measured value soil moisture	Actuating value by ascending actual value	<input type="radio"/> increasing <input checked="" type="radio"/> decreasing
Controller soil moisture	Controller	Switched PI controller (PWM)
Measured value soil temperature	Setpoint (x 0,01 °C)	1800
Controller soil temperature	Proportional range (°C)	5
Dewpoint temperature	Reset time (in minutes)	150
Absolute humidity	Actuating value send cyclical	<input checked="" type="radio"/> No <input type="radio"/> Yes
Humidity	Actuating value distance to limit in %	0
Controller humidity	Cycle duration in seconds	60
Air temperature	Use clock timer	<input checked="" type="radio"/> No <input type="radio"/> Yes

Parameter Switched PI controller (PWM)	Settings / Description
Locking object	1 / 0 lock the controller at "1" oder "0"
Actuating value by ascending actual value	increasing / decreasing control direction
Controller	Select controller type
Setpoint (x 0,01°C)	-9999 .. 9999 Note any changes due to auxiliary variables.
Proportional range (x 0,01°C)	-9999 .. 9999
Reset time (in Minuten)	0 .. 255
Actuating value send cyclical	No / Yes
Actuating value distance to limit in %	0 .. 50
Cycle duration in seconds	0 .. 65535
Use clock timer	No / Yes The time is set in the 'General settings' parameter field.

Soil temperature - Two-Position Controller

General settings	Locking object	<input checked="" type="radio"/> locked if 1 <input type="radio"/> locked if 0
Measured value soil moisture	Actuating value by ascending actual value	<input type="radio"/> increasing <input checked="" type="radio"/> decreasing
Controller soil moisture	Controller	Two-Position Controller
Measured value soil temperature	Setpoint (x 0,01 °C)	1800
Controller soil temperature	Differential gap Controller (°C)	5
Dewpoint temperature	Actuating value send cyclical	<input checked="" type="radio"/> No <input type="radio"/> Yes
Absolute humidity	Use clock timer	<input checked="" type="radio"/> No <input type="radio"/> Yes

Parameter Two-Position Controller	Settings / Description
Locking object	1 / 0 lock the controller at "1" oder "0"
Actuating value by ascending actual value	increasing / decreasing control direction
Controller	Select controller type
Setpoint (x 0,01°C)	-9999 .. 9999 Note any changes due to auxiliary variables.
Differential gab Controller (x 0,01°C)	-9999 .. 9999 The switching point hysteresis is symmetrical above the setpoint.
Actuating value send cyclical	No / Yes
Use clock timer	No / Yes The time is set in the 'General settings' parameter field.

Soil temperature - Two-Position Controller Pulsed

General settings	Locking object	<input checked="" type="radio"/> locked if 1 <input type="radio"/> locked if 0
Measured value soil moisture	Actuating value by ascending actual value	<input type="radio"/> increasing <input checked="" type="radio"/> decreasing
Controller soil moisture	Controller	Two-Position Controller Pulsed
Measured value soil temperature	Setpoint (x 0,01 °C)	1800
Controller soil temperature	Differential gap Controller (°C)	5
Dewpoint temperature	Actuating value send cyclical	<input checked="" type="radio"/> No <input type="radio"/> Yes
Absolute humidity	Duty cycle in %	0
Humidity	Cycle duration in seconds	60
	Use clock timer	<input checked="" type="radio"/> No <input type="radio"/> Yes

Parameter Two-Position Controller Pulsed	Settings / Description
Locking object	1 / 0 lock the controller at "1" oder "0"
Actuating value by ascending actual value	increasing / decreasing control direction
Controller	Select controller type
Setpoint (x 0,01°C)	-9999 .. 9999 Note any changes due to auxiliary variables.
Schaltdifferenz Regler (x 0,01°C)	-9999 .. 9999 The switching point hysteresis is symmetrical above the setpoint.
Actuating value send cyclical	No / Yes
Duty cycle in %	0 .. 50
Cycle duration in seconds	0 .. 65535
Use clock timer	No / Yes The time is set in the 'General settings' parameter field.

Dewpoint temperature

General settings	Measured value send cyclical	<input checked="" type="radio"/> No <input type="radio"/> Yes
Measured value soil moisture	Measured value send by change	<input checked="" type="radio"/> No <input type="radio"/> Yes
Controller soil moisture	Type datapoint	2byte float
Measured value soil temperature	Auxiliary object is	<input checked="" type="radio"/> Upper limit <input type="radio"/> Lower limit
Controller soil temperature	Auxiliary value store by change	<input checked="" type="radio"/> No <input type="radio"/> Yes
Dewpoint temperature	Lower limit (x 0,01 °C)	0
Absolute humidity	Upper limit (x 0,01 °C)	1500
Humidity	Differential gap send/limits (x 0,01 °C)	50

Parameter Dewpoint temperature	Settings / Description
Measured value send cyclical	No / Yes
Measured value send by change	No / Yes
Type datapoint	KNX data type for measured value
Auxiliary object is	- Setpoint - Upper limit - Lower limit Parameter that can be changed via the auxiliary object.
Auxiliary value store by change	No / Yes
Lower limit (x 0,01 °C)	-9999 .. 9999 If the measured value is below this limit, the object 'lower limit' is set. Note any changes due to auxiliary variables.
Upper limit (x 0,01 °C)	-9999 .. 9999 If the measured value exceeds this limit, the object 'upper limit' is set. Note any changes due to auxiliary variables.
Differential gap send/limits (x 0,01 °C)	-9999 .. 9999 Is symmetrically above the limit values as hysteresis.

Absolute humidity

General settings	Measured value send cyclical	<input checked="" type="radio"/> No <input type="radio"/> Yes
Measured value soil moisture	Measured value send by change	<input checked="" type="radio"/> No <input type="radio"/> Yes
Controller soil moisture	Type datapoint	2byte float
Measured value soil temperature	Auxiliary object is	<input checked="" type="radio"/> Upper limit <input type="radio"/> Lower limit
Controller soil temperature	Auxiliary value store by change	<input checked="" type="radio"/> No <input type="radio"/> Yes
Dewpoint temperature	Lower limit (x 0,01 g/m ³)	700
	Upper limit (x 0,01 g/m ³)	1700
Absolute humidity	Differential gap send/limits (x 0,01 g/m ³)	50
Humidity		

Parameter Absolute humidity	Settings / Description
Measured value send cyclical	No / Yes
Measured value send by change	No / Yes
Type datapoint	KNX data type for measured value
Auxiliary object is	- Setpoint - Upper limit - Lower limit Parameter that can be changed via the auxiliary object.
Auxiliary value store by change	No / Yes
Lower limit (x 0,01 g/m ³)	-9999 .. 9999 If the measured value is below this limit, the object 'lower limit' is set. Note any changes due to auxiliary variables.
Upper limit (x 0,01 g/m ³)	-9999 .. 9999 If the measured value exceeds this limit, the object 'upper limit' is set. Note any changes due to auxiliary variables.
Differential gap send/limits (x 0,01 g/m ³)	-9999 .. 9999 Is symmetrically above the limit values as hysteresis.

Humidity

General settings	Measured value send cyclical	<input checked="" type="radio"/> No <input type="radio"/> Yes
Measured value soil moisture	Measured value send by change	<input checked="" type="radio"/> No <input type="radio"/> Yes
Controller soil moisture	Auxiliary object is	Setpoint
Measured value soil temperature	Auxiliary value store by change	<input checked="" type="radio"/> No <input type="radio"/> Yes
Controller soil temperature	Lower limit (%)	30
Dewpoint temperature	Upper limit (%)	80
Absolute humidity	Differential gap send/limits (%)	5

Humidity

Parameter Humidity	Settings / Description
Measured value send cyclical	No / Yes
Measured value send by change	No / Yes
Auxiliary object is	- Setpoint - Upper limit - Lower limit Parameter that can be changed via the auxiliary object.
Auxiliary value store by change	No / Yes
Lower limit (%)	0 .. 100 If the measured value is below this limit, the object 'lower limit' is set. Note any changes due to auxiliary variables.
Upper limit (%)	0 .. 100 If the measured value exceeds this limit, the object 'upper limit' is set. Note any changes due to auxiliary variables.
Differential gap send/limits (%)	0 .. 100 Is symmetrically above the limit values as hysteresis.

Controller humidity / variants

Humidity - Steady PI controller

General settings	Locking object	<input checked="" type="radio"/> locked if 1 <input type="radio"/> locked if 0
Measured value soil moisture	Actuating value by ascending actual value	<input type="radio"/> increasing <input checked="" type="radio"/> decreasing
Controller soil moisture	Controller	Steady PI controller
Measured value soil temperature	Setpoint (%)	50
Controller soil temperature	Proportional range (%)	5
Dewpoint temperature	Reset time (in minutes)	150
Absolute humidity	Actuating value send cyclical	<input checked="" type="radio"/> No <input type="radio"/> Yes
Humidity	Actuating value distance to limit in %	0
	Use clock timer	<input checked="" type="radio"/> No <input type="radio"/> Yes

[Controller humidity](#)

Parameter Steady PI controller	Settings / Description
Locking object	1 / 0 lock the controller at "1" oder "0"
Actuating value by ascending actual value	increasing / decreasing control direction
Controller	Select controller type
Setpoint (in %)	0 .. 100 Note any changes due to auxiliary variables.
Proportional range (in %)	0 .. 100
Reset time (in minutes)	0 .. 255
Actuating value send cyclical	No / Yes
Actuating value distance to limit in %	0 .. 50
Use clock timer	No / Yes The time is set in the 'General settings' parameter field.

Humidity - Switched PI controller (PWM)

General settings	Locking object	<input checked="" type="radio"/> locked if 1 <input type="radio"/> locked if 0
Measured value soil moisture	Actuating value by ascending actual value	<input type="radio"/> increasing <input checked="" type="radio"/> decreasing
Controller soil moisture	Controller	Switched PI controller (PWM)
Measured value soil temperature	Setpoint (%)	50
Controller soil temperature	Proportional range (%)	5
Dewpoint temperature	Reset time (in minutes)	150
Absolute humidity	Actuating value send cyclical	<input checked="" type="radio"/> No <input type="radio"/> Yes
Humidity	Actuating value distance to limit in %	0
Controller humidity	Cycle duration in seconds	60
Air temperature	Use clock timer	<input checked="" type="radio"/> No <input type="radio"/> Yes

Parameter Switched PI controller (PWM)	Settings / Description
Locking object	1 / 0 lock the controller at "1" oder "0"
Actuating value by ascending actual value	increasing / decreasing control direction
Controller	Select controller type
Setpoint (in %)	0 .. 100 Note any changes due to auxiliary variables.
Proportional range (in %)	0 .. 100
Reset time (in minutes)	0 .. 255
Actuating value send cyclical	No / Yes
Actuating value distance to limit in %	0 .. 50
Cycle duration in seconds	0 .. 65535
Use clock timer	No / Yes The time is set in the 'General settings' parameter field.

Humidity - Two-Position Controller

General settings	Locking object	<input checked="" type="radio"/> locked if 1 <input type="radio"/> locked if 0
Measured value soil moisture	Actuating value by ascending actual value	<input type="radio"/> increasing <input checked="" type="radio"/> decreasing
Controller soil moisture	Controller	Two-Position Controller
Measured value soil temperature	Setpoint (%)	50
Controller soil temperature	Differential gap Controller (%)	5
Dewpoint temperature	Actuating value send cyclical	<input checked="" type="radio"/> No <input type="radio"/> Yes
Absolute humidity	Use clock timer	<input checked="" type="radio"/> No <input type="radio"/> Yes
Humidity		

Controller humidity

Parameter Two-Position Controller	Settings / Description
Locking object	1 / 0 lock the controller at "1" oder "0"
Actuating value by ascending actual value	increasing / decreasing control direction
Controller	Select controller type
Setpoint (in %)	0 .. 100 Note any changes due to auxiliary variables.
Differential gab Controller (in %)	0 .. 100 The switching point hysteresis is symmetrical above the setpoint.
Actuating value send cyclical	No / Yes
Use clock timer	No / Yes The time is set in the 'General settings' parameter field.

Humidity - Two-Position Controller Pulsed

General settings	Locking object	<input checked="" type="radio"/> locked if 1 <input type="radio"/> locked if 0
Measured value soil moisture	Actuating value by ascending actual value	<input type="radio"/> increasing <input checked="" type="radio"/> decreasing
Controller soil moisture	Controller	Two-Position Controller Pulsed
Measured value soil temperature	Setpoint (%)	50
Controller soil temperature	Differential gap Controller (%)	5
Dewpoint temperature	Actuating value send cyclical	<input checked="" type="radio"/> No <input type="radio"/> Yes
Absolute humidity	Duty cycle in %	0
Humidity	Cycle duration in seconds	60
	Use clock timer	<input checked="" type="radio"/> No <input type="radio"/> Yes

Controller humidity

Parameter Two-Position Controller Pulsed	Settings / Description
Locking object	1 / 0 lock the controller at "1" oder "0"
Actuating value by ascending actual value	increasing / decreasing control direction
Controller	Select controller type
Setpoint (in %)	0 .. 100 Note any changes due to auxiliary variables.
Differential gab Controller (in %)	0 .. 100 The switching point hysteresis is symmetrical above the setpoint.
Actuating value send cyclical	No / Yes
Duty cycle in %	0 .. 50
Cycle duration in seconds	0 .. 65535
Use clock timer	No / Yes The time is set in the 'General settings' parameter field.

Air temperature

General settings	Measured value send cyclical	<input checked="" type="radio"/> No <input type="radio"/> Yes
Measured value soil moisture	Measured value send by change	<input checked="" type="radio"/> No <input type="radio"/> Yes
Controller soil moisture	Type datapoint	2byte float
Measured value soil temperature	Auxiliary object is	Setpoint
Controller soil temperature	Auxiliary value store by change	<input checked="" type="radio"/> No <input type="radio"/> Yes
Dewpoint temperature	Lower limit (x 0,01 °C)	700
Absolute humidity	Upper limit (x 0,01 °C)	1700
Humidity	Measured value shift (x 0,01 °C)	0
Controller humidity	Differential gap send/limits (x 0,01 °C)	50

Air temperature

Parameter Air temperature	Settings / Description
Measured value send cyclical	No / Yes
Measured value send by change	No / Yes
Type datapoint	KNX data type for measured value
Auxiliary object is	- Setpoint - Upper limit - Lower limit Parameter that can be changed via the auxiliary object.
Auxiliary value store by change	No / Yes
Lower limit (x 0,01°C)	-9999 .. 9999 If the measured value is below this limit, the object 'lower limit' is set. Note any changes due to auxiliary variables.
Upper limit (x 0,01°C)	-9999 .. 9999 If the measured value exceeds this limit, the object 'upper limit' is set. Note any changes due to auxiliary variables.
Measured value shift (x 0,01°C)	-32768 .. 32767
Differential gap send/limits (x 0,01°C)	-9999 .. 9999 Is symmetrically above the limit values as hysteresis.

Controller air temperature / variants

Air temperature - Steady PI controller

General settings	Locking object	<input checked="" type="radio"/> locked if 1 <input type="radio"/> locked if 0
Measured value soil moisture	Actuating value by ascending actual value	<input type="radio"/> increasing <input checked="" type="radio"/> decreasing
Controller soil moisture	Controller	Steady PI controller
Measured value soil temperature	Setpoint (x 0,01 °C)	1800
Controller soil temperature	Proportional range (in °C)	5
Dewpoint temperature	Reset time (in minutes)	150
Absolute humidity	Actuating value send cyclical	<input checked="" type="radio"/> No <input type="radio"/> Yes
Humidity	Actuating value distance to limit in %	0
Controller humidity	Use clock timer	<input checked="" type="radio"/> No <input type="radio"/> Yes
Air temperature		

[Controller air temperature](#)

Parameter Steady PI controller	Settings / Description
Locking object	1 / 0 lock the controller at "1" oder "0"
Actuating value by ascending actual value	increasing / decreasing control direction
Controller	Select controller type
Setpoint (x 0,01°C)	-9999 .. 9999 Note any changes due to auxiliary variables.
Proportional range (x 0,01°C)	-9999 .. 9999
Reset time (in minutes)	0 .. 255
Actuating value send cyclical	No / Yes
Actuating value distance to limit %	0 .. 50
Use clock timer	No / Yes The time is set in the 'General settings' parameter field.

Air temperature - Switched PI controller (PWM)

General settings	Locking object	<input checked="" type="radio"/> locked if 1 <input type="radio"/> locked if 0
Measured value soil moisture	Actuating value by ascending actual value	<input type="radio"/> increasing <input checked="" type="radio"/> decreasing
Controller soil moisture	Controller	Switched PI controller (PWM)
Measured value soil temperature	Setpoint (x 0,01 °C)	1800
Controller soil temperature	Proportional range (in °C)	5
Dewpoint temperature	Reset time (in minutes)	150
Absolute humidity	Actuating value send cyclical	<input checked="" type="radio"/> No <input type="radio"/> Yes
Humidity	Actuating value distance to limit in %	0
Controller humidity	Cycle duration in seconds	60
Air temperature	Use clock timer	<input checked="" type="radio"/> No <input type="radio"/> Yes

[Controller air temperature](#)

Parameter Switched PI controller (PWM)	Settings / Description
Locking object	1 / 0 lock the controller at "1" oder "0"
Actuating value by ascending actual value	increasing / decreasing control direction
Controller	Select controller type
Setpoint (x 0,01°C)	-9999 .. 9999 Note any changes due to auxiliary variables.
Proportional range (x 0,01°C)	-9999 .. 9999
Reset time (in minutes)	0 .. 255
Actuating value send cyclical	No / Yes
Actuating value distance to limit %	0 .. 50
Cycle duration in seconds	0 .. 65535
Use clock timer	No / Yes The time is set in the 'General settings' parameter field.

Air temperature - Two-Position Controller

General settings	Locking object	<input checked="" type="radio"/> locked if 1 <input type="radio"/> locked if 0
Measured value soil moisture	Actuating value by ascending actual value	<input type="radio"/> increasing <input checked="" type="radio"/> decreasing
Controller soil moisture	Controller	Two-Position Controller
Measured value soil temperature	Setpoint (x 0,01 °C)	1800
Controller soil temperature	Differential gap Controller (in °C)	5
Dewpoint temperature	Actuating value send cyclical	<input checked="" type="radio"/> No <input type="radio"/> Yes
Absolute humidity	Use clock timer	<input checked="" type="radio"/> No <input type="radio"/> Yes
Humidity		
Controller humidity		
Air temperature		

[Controller air temperature](#)

Parameter Two-Position Controller	Settings / Description
Locking object	1 / 0 lock the controller at "1" oder "0"
Actuating value by ascending actual value	increasing / decreasing control direction
Controller	Select controller type
Setpoint (x 0,01°C)	-9999 .. 9999 Note any changes due to auxiliary variables.
Differential gab Controller (x 0,01°C)	-9999 .. 9999 The switching point hysteresis is symmetrical above the setpoint.
Actuating value send cyclical	No / Yes
Use clock timer	No / Yes The time is set in the 'General settings' parameter field.

Air temperature - Two-Position Controller Pulsed

General settings	Locking object	<input checked="" type="radio"/> locked if 1 <input type="radio"/> locked if 0
Measured value soil moisture	Actuating value by ascending actual value	<input type="radio"/> increasing <input checked="" type="radio"/> decreasing
Controller soil moisture	Controller	Two-Position Controller Pulsed
Measured value soil temperature	Setpoint (x 0,01 °C)	1800
Controller soil temperature	Differential gap Controller (in °C)	5
Dewpoint temperature	Actuating value send cyclical	<input checked="" type="radio"/> No <input type="radio"/> Yes
Absolute humidity	Duty cycle in %	0
Humidity	Cycle duration in seconds	60
Controller humidity	Use clock timer	<input checked="" type="radio"/> No <input type="radio"/> Yes
Air temperature		

[Controller air temperature](#)

Parameter Two-Position Controller Pulsed	Settings / Description
Locking object	1 / 0 lock the controller at "1" oder "0"
Actuating value by ascending actual value	increasing / decreasing control direction
Controller	Select controller type
Setpoint (x 0,01°C)	-9999 .. 9999 Note any changes due to auxiliary variables.
Differential gab Controller (x 0,01°C)	-9999 .. 9999 The switching point hysteresis is symmetrical above the setpoint.
Actuating value send cyclical	No / Yes
Duty cycle in %	0 .. 50
Cycle duration in seconds	0 .. 65535
Use clock timer	No / Yes The time is set in the 'General settings' parameter field.

Status objects

Status objects are used to monitor properties.

- Object 8 : status soil moisture
- Object 15 : status soil temperature
- Object 50 : status relative humidity
- Object 57 : status air temperature

Description	Bit-No.	Hexadecimal	Dezimal
Upper limit value exceeded	0	\$01	1
Lower limit value undershot	1	\$02	2
manipulated variable unequal NULL	2	\$04	4
Lock active	3	\$08	8
Auxiliary variable is stored	4	\$10	16
Timer active	5	\$20	32

The values of the individual bits are added together and output as 1 byte on the bus.

The 'Error code' object is no longer used.

ETS Objects

Number	Name	Object Function	Length	Data Type
0	Output, Error code	Error code	4 bytes	
2	Output, measured value soil moisture	Measured value	2 bytes	temperature (°C), temperature (°C)
3	Input, auxiliary object soil moisture	Auxiliary object	2 bytes	temperature (°C), temperature (°C)
4	Output, upper limit soil moisture	Exceeding limit	1 bit	boolean
5	Output, lower limit soil moisture	Undercut limit	1 bit	boolean
6	Output, controller soil moisture	Actuating value	1 bit	switch, switch
7	Input, enable/lock controller	Enable/lock	1 bit	switch
8	Output, status object soil moisture	Status	1 byte	
9	Output, soil temperature	Measured value	2 bytes	temperature (°C), temperature (°C)
10	Input, auxiliary object soil temperature	Auxiliary object	2 bytes	temperature (°C), temperature (°C)
11	Output, upper limit soil temperature	Limit	1 bit	switch
12	Output, lower limit soil temperature	Limit	1 bit	switch
13	Output, controller soil temperature	Actuating value	1 bit	switch, switch
14	Input, enable/lock soil temperature	Enable/lock	1 bit	switch
15	Output, status object soil temperature	Channel status	1 byte	
30	Output, measured value dewpoint temperature	Calculated value	2 bytes	temperature (°C), temperature (°C)
31	Input, auxiliary object dewpoint temperature	Auxiliary object	2 bytes	temperature (°C), temperature (°C)
32	Output, upper limit dewpoint temperature	Limit	1 bit	switch
33	Output, lower limit dewpoint temperature	Limit	1 bit	switch
37	Output, measured value absolute humidity	Calculated value	2 bytes	temperature (°C), temperature (°C)
38	Input, auxiliary object absolute humidity	Auxiliary object	2 bytes	temperature (°C), temperature (°C)
39	Output, upper limit absolute humidity	Limit	1 bit	switch
40	Output, lower limit absolute humidity	Limit	1 bit	switch
44	Output, measured value relative humidity	Measured value	2 bytes	temperature (°C), temperature (°C)
45	Input, auxiliary object relative humidity	Auxiliary object	2 bytes	temperature (°C), temperature (°C)
46	Output, upper limit relative humidity	Limit	1 bit	switch
47	Output, lower limit relative humidity	Limit	1 bit	switch
48	Output, controller relative humidity	Actuating value	1 bit	switch, switch
49	Input, enable/lock relative humidity	Enable/lock	1 bit	switch
50	Output, Object status relative humidity	Channel status	1 byte	
51	Output, measured value air temperature	Measured value	2 bytes	temperature (°C), temperature (°C)
52	Input, auxiliary object air temperature	Auxiliary object	2 bytes	temperature (°C), temperature (°C)
53	Output, upper limit air temperature	Limit	1 bit	switch
54	Output, lower limit air temperature	Limit	1 bit	switch
55	Output, controller K8	Actuating value	1 bit	switch, switch
56	Input, enable/lock air temperature	Enable/lock	1 bit	switch
57	Output, Object status air temperature	Channel status	1 byte	
58	Time	Time	3 bytes	time of day
59	Date	Date	3 bytes	date

Notes

Use of controllers

In applications with very large control paths - i.e. when there is a considerable delay between the change in a control value and the measurable response of the system - conventional control quickly reaches its limits. In such cases, simple P or PI controllers in particular often react too late or with excessive correction, which can lead to instabilities, oscillations or inefficient behaviour.

In such cases, a **time-controlled countermeasure** can be more sensible and robust. Instead of reacting continuously to a measured value, the control takes place at fixed intervals or according to defined schedules. This is particularly advantageous if the system behaviour is well known and relatively constant.

Controller

The control can be carried out via PI or two-point control, also with pulsed outputs. The pulsed two-point controller operates with a constant duty cycle, which is fixedly parameterized as is the period duration. The duty cycle of the pulsed PI controller is variable and depends on the manipulated variable

(Pulse width modulation). The controller calculates the control variable to be output every second. It can always be read out in real time and is output cyclically by the continuous PI controller (Value can be parameterized). The integral component regulates a control deviation to 0 over time.

Continuous PI control

A PI control is an algorithm that consists of a proportional and an integral component. By combining these two components, a fast yet accurate adjustment of the manipulated variable can be achieved.

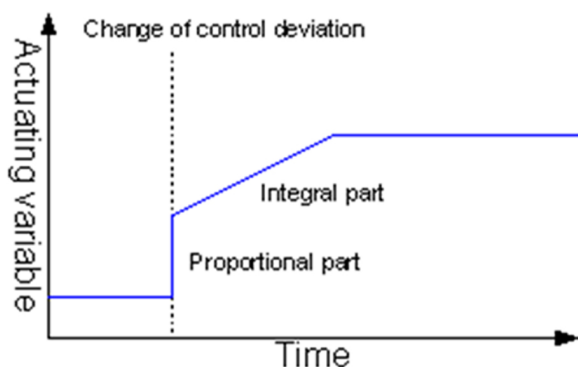

Switched PI controller (PWM)

The control is analogous to the PI controller. The manipulated variable is output in pulsed form. In PWM control, the parameterized period duration determines the transmission interval. This results in a permanent switching on and off within the period, whereby a constant valve position is achieved on average. The touch ratio is determined indirectly via the reset time (integration time).

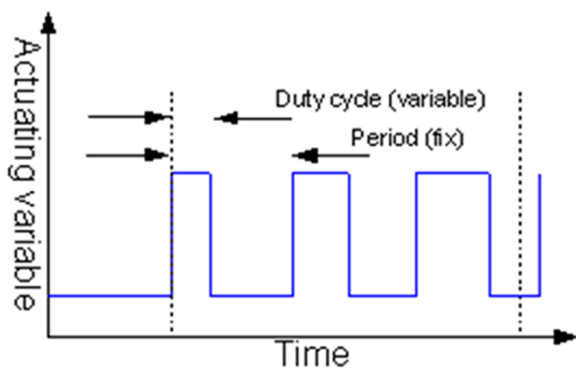

General rules for setting the PI parameters

The reset time must be significantly greater than the time constant of the controlled system.
The proportional band corresponds to the gain of the control loop.
The smaller the proportional band, the greater the gain.

Parameter specification	Effect
lower proportional band	Quick adjustment to the setpoint Large overshoot during setpoint compensation (possibly also continuous oscillation)
high proportional band	Slow correction of the control deviation No or little overshoot
short reset time (Integration time)	Fast correction of control deviations Danger of continuous vibrations
long reset time (Integration time)	Slow correction of control deviations Low risk of over- or continuous vibrations

Two-point controller

The two-point control is a very simple type of control. As soon as the actual value deviates from the setpoint (\pm half the switching difference), a switch-on or switch-off object is sent to the bus. Make the switching differential large enough to keep the bus load low. Configure the switching differential small enough to avoid extreme actual value fluctuations. The two-point controller is parameterized via the setpoint and the switching differential.

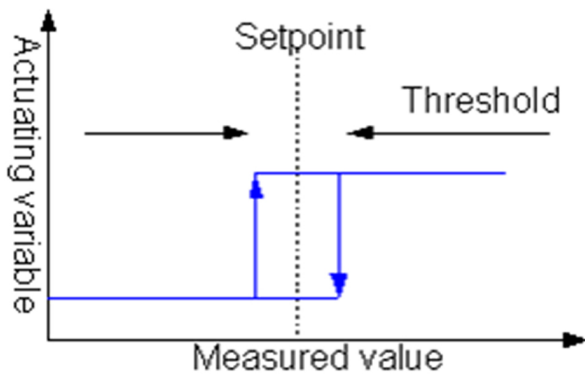

Two-point controller with pulsed output

The control is analogous to the two-point controller. The manipulated variable is output in pulsed form. With a duty cycle of 40% and a period of 10 minutes, the object is repeatedly switched on for 4 minutes and off for 6 minutes.

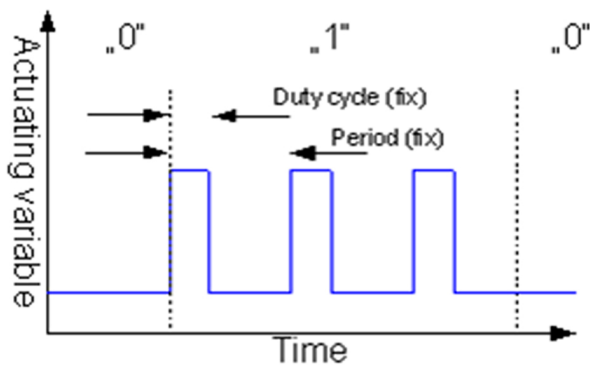

In Case of Bus Voltage Recurrence

All changes made via the KNX bus are retained if the device has been parameterized accordingly. The measurement and controller values start with their current values (for PI controllers with an integral component of 0). The ETS parameter settings are retained.

Discharge Program and Reset Sensor

To delete the programming (project planning) or to reset the module to the delivery status, it must be disconnected from the power supply (disconnect the KNX bus voltage). Now press and hold the programming button while reconnecting the KNX bus voltage and wait until the programming LED lights up (approx. 1-2 seconds). Now you can release the programming button again and the module is ready for a new configuration.

If you release the programming button too early, repeat the procedure.

Imprint

Editor: Arcus-EDS GmbH, Rigaer Str. 88, 10247 Berlin

Responsible for the content: Hjalmar Hevers, Sascha Bergmann

Reprint, also in part, only permitted with the approval of Arcus-EDS GmbH.

All information without guarantee, technical changes and price changes reserved.

Liability

The selection of the devices and the determination of the suitability of the devices for a certain intended use are only in the buyer's responsibility. For this there is none liability or warranty assumed. The information in the catalogs and data sheets is not an assurance of special properties, but result from experience and measurements. Liability for damage caused by incorrect operation/project planning or malfunctions of the devices is excluded. Rather, the operator/projector must ensure that incorrect operation, misconceptions and malfunctions cannot cause any further damage.

Safety regulations

Danger! Installation and assembly of electrical devices may only be carried out by an electrical specialist. Compliance with the corresponding safety regulations of the VDE, TÜV and the responsible Energy supply companies must be ensured by the buyer/operator of the system. No guarantee is assumed for defects and damage caused by improper use of the devices or by not observing the operating instructions.

Warranty

We provide warranty within the scope of the legal provisions. In the event of a malfunction, please contact us and send the device with an error description Our company address mentioned below.

Manufacturer



Arcus-EDS GmbH
Rigaer Str. 88
10247 Berlin

Disposal



The symbol of the crossed -out garbage bin on the device or the packaging means that the product at the end of his service life may not be disposed of with other general waste.

Registered trademarks



The CE sign is a free traffic sign that turns exclusively to the authority and none Assurance of properties.



Registered trademark of the Konnex Association